

Gina Shim, 2017

Volume 3 Issue 3, pp. 173-184

Date of Publication: 13<sup>th</sup> December 2017

DOI-<https://dx.doi.org/10.20319/mijst.2017.33.173184>

This paper can be cited as: Shim, G. (2017). The Effect of Impulse on a Falling Rod-Chain. MATTER: International Journal of Science and Technology, 3(3), 173-184.

This work is licensed under the Creative Commons Attribution-Non Commercial 4.0 International License. To view a copy of this license, visit <http://creativecommons.org/licenses/by-nc/4.0/> or send a letter to Creative Commons, PO Box 1866, Mountain View, CA 94042, USA.

## THE EFFECT OF IMPULSE ON A FALLING ROD-CHAIN

**Gina Shim**

Cheong Shim International Academy, Gyeonggi-do, South Korea  
[geenazzang@gmail.com](mailto:geenazzang@gmail.com)

---

### Abstract

*When a chain with a tilted rod collides with the horizontal surface, the chain falls faster than when it free falls. If one moving object collides with a rigid object, then the velocity of the moving object is supposed to become slower. However, in the case of this phenomenon, the impulse from the colliding section determines the acceleration of the falling chain. This system is mostly related to change in momentum, so the calculation of the change in velocity throughout the phenomenon was done with linear momentum and angular momentum theories. After making a theoretical equation, the calculated acceleration was compared with experimental acceleration.*

### Keywords

Impulse, Angular Momentum, Linear Momentum, Falling Chain, Rod-Chain

---

### 1. Introduction

When we drop a chain with a tilted rod, it falls faster than a free fall. From this phenomenon, we can assume that there is a change in acceleration and force while the chain is falling. The net external force is getting greater as the rod at the bottom of the chain collides on the horizontal surface, so the chain reaches an acceleration greater than gravitational acceleration. The picture below is comparing the colliding rod-chain and the non-colliding rod-

chain. The rod on the very top of the colliding chain on left one is certainly falling faster than that of non-colliding chain on right one.

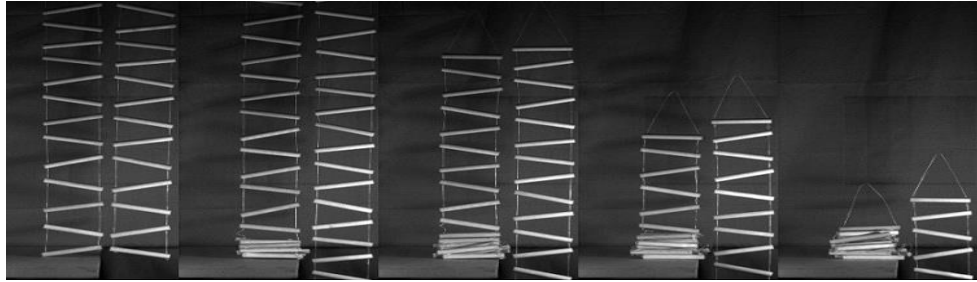

**Figure 1:** The chain on the left is colliding and the chain on the right is free falling. They were let go at the same time, but the one on the left is falling faster than the one on the right (credit: Ruina lab)

## 1.1 Objective

The objective of this research is to find the change in acceleration to explain this fast chain phenomenon and also examine the parameters. The equation considers many of the independent variables that may affect the force (change in momentum, impulse): angle of which the rod is tilted, length between the rods, and number of the rod.

## 2. Theory

The chain could be divided into three parts: falling, colliding, and accumulating. The tension from the string attached to the colliding rod is pulling down the rest of the sections still falling. According to the assumption that the collision of rod and the horizontal surface is sticking collision, the accumulated pile has no influence on the rest of the falling chain. Sticking collision is rods not bouncing back up after it hits the surface or collides with another rod.

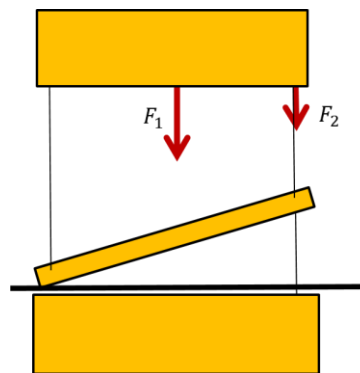

**Figure 2:** Two forces are working on the chain:  $F_1$  is the gravitational force and  $F_2$  is the tension of the string connecting two rods

There are two forces acting on the falling section: gravitational force ( $F_1$ ) and tension ( $F_2$ ).  $\Delta t$  is the change in time before and after the collision;  $M$  is the mass of the whole chain, and  $\Delta v$  is the change in velocity before and after the collision. Assume that the weight of the string is negligible and  $n$  is the number of chains left. If  $\rho$  is the density of each rod  $\frac{\text{total mass of chain}}{\text{total length of chain}}$ , then we can write  $M = \rho(L - x)$ .  $L$  is the total length and  $x$  is the length of already fallen chain.

$$(F_1 + F_2)\Delta t = (M)\Delta v \quad (1)$$

$$(F_1 + F_2) = (\rho v^2) \quad (2)$$

$$a = g + \left(\frac{F_2}{F_1 + F_2}\right) \frac{\dot{x}^2}{(L-x)} \quad (3)$$

The section of Equation 3 added to  $g$ , the gravitational acceleration, proves the existence of a different force pulling on the falling chain other than the gravitational force.

## 2.1 Angular Momentum

Each rod has mass of  $m$  and length of  $L$ , and is moving vertically downward with velocity  $v$  onto a rigid horizontal surface. On the link about to hit the surface, point B speeds up as point A hits the surface because of the angular momentum balance about point A. This means the point B hits the surface with greater velocity than that of point A, and this sequence will continue on With the Rest of the Chain.

Consider The Upper Part Of The Chain As A One Lump Of Mass Of  $M$ . As Point A Collides (assumption: sticking collision), the ground provides a normal impulse  $I_1$  and point B pulls down string attached to the upper chain with an impulse  $I_2$ . Then, eventually, the last link to hit the ground loses all its momentum by an impulse  $I_3$ . According to linear and angular momentum balance, as well as to post-collisional equality between velocity of point B and mass  $M$ , these impulses are:

$$I_1 = \frac{mv}{3} \quad (4)$$

$$I_2 = \frac{mv}{6} \quad (5)$$

$$I_3 = \frac{mv}{2} \quad (6)$$

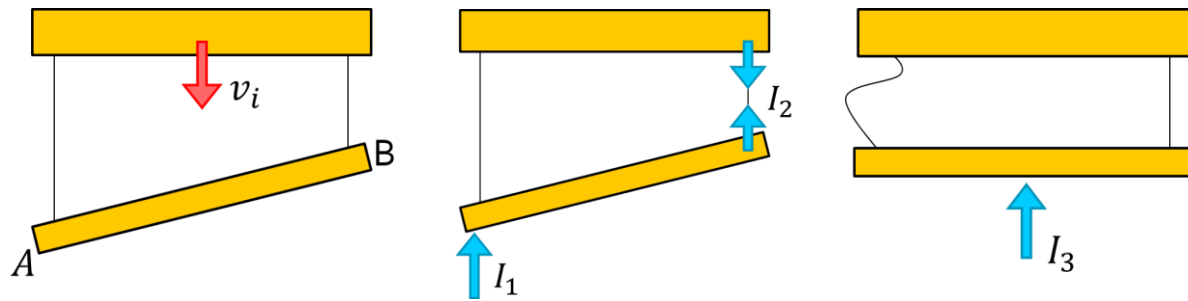

**Figure 3:** Before a rod comes to a complete stop, there are three impulses while the rod hits the horizontal surface. The first one occurs when the lower end of the rod hits the horizontal surface, and the second impulse when the colliding rod pulls on the string attached to the rest of the chain. Lastly, the third impulse stops the rod completely.

When a single rod is colliding, there are three impulses which bring the rod to stop. The first impulse  $I_1$  happens when point A hits the horizontal surface; the second impulse  $I_2$  occurs when point B is pulled by the string connected to the rest of the chain; third impulse  $I_3$  is when the whole body of the rod hits the horizontal surface and comes to stop (sticking collision so no bouncing back up). Defining these impulses with equation of known variable is necessary (Anoop Grewal et al., 2011).

## 2.2 Linear Momentum

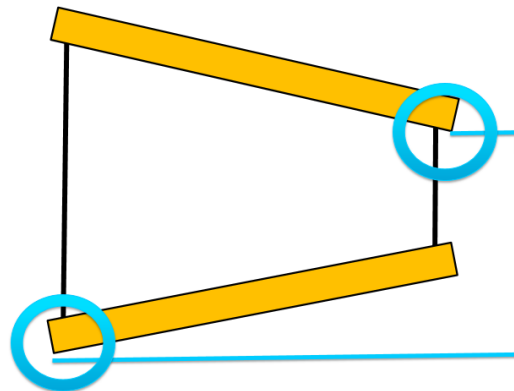

**Figure 4:** The calculation is done link by link. The strategy is to calculate the change in velocity of that one section and work the way up the falling chain. One section includes one colliding rod and the shorter one of two string part (free falling part)

The change of velocity of the total chain can be calculated using the linear momentum. In order to find the change in moment between collisions, new velocity of point A in each link should be known. Also, impulses during the collision was calculated using the angular momentum theory. Note that all velocity refers to the velocity of the center of the rod.

$$(I_1 - I_2) = \frac{1}{6}mv_i \cos \theta \quad (7)$$

$m$  represents the mass of a single rod,  $n$  represents the number of rod left on the falling section of the chain, and  $v_i$  is the velocity of the chain right before the rod hits the horizontal surface. Thus, the momentum of the falling chain can be written as  $nmv_i$ . This equation calculates the impulse(=change in linear momentum) when the rod collides on the horizontal surface. Therefore, each time a rod collides, that much of momentum is added to the total momentum, which gives us the following equation.

$$nmv_i + \frac{1}{6}mv_i \cos \theta \quad (8)$$

If the momentum equation (8) is divided by  $nm$ , the velocity after the collision  $v_c$  results as equation (9).

$$v_c = v_i + \frac{v_i}{6n} \cos \theta \quad (9)$$

Now that we know the change of velocity during the collision, we can also calculate the velocity changed during the free fall of the string section. (Assuming the string's weight is negligible.)

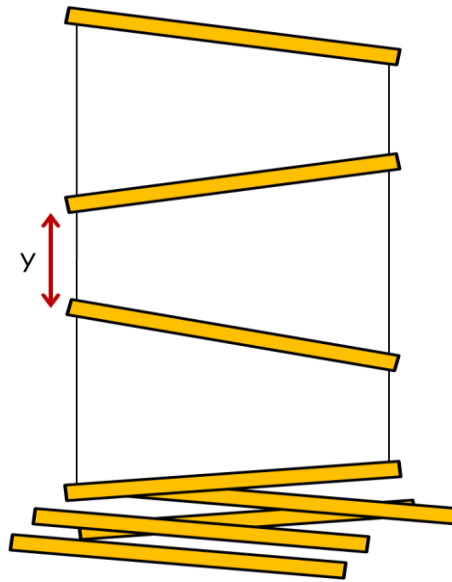

**Figure 5:** Full chain falling. In this case, the  $n$  would be three, and  $y$  is shown.

$$v_f = \sqrt{v_c^2 + 2gy} \quad (10)$$

The linear momentum change during the free fall is

$$nm(v_f - v_c) = \sqrt{v_c^2 + 2gy} - v_c \quad (11)$$

The linear momentum after the free fall is

$$nmv_c + mn(\sqrt{v_c^2 + 2gy} - v_c) = nm\sqrt{v_c^2 + 2gy} \quad (12)$$

Therefore, the new velocity right before the next collision can be calculated by dividing the  $nm$  from the momentum and substituting  $v_c$  with the defined equation (8).

$$v_{i\ new} = \sqrt{\left(v_i + \frac{v_i}{6n} \cos \theta\right)^2 + 2gy} \quad (13)$$

That means the change of linear velocity of the total chain is

$$\Delta v = v_i - v_{i\ new} \quad (14)$$

To calculate the acceleration after each fall, the following equation was used.

$$v_f^2 - v_i^2 = 2aS \quad (15)$$

Although the force changes as each collision happens, the instant of a single collision is very fast. Since the collision happens in a very short time, it is appropriate to assume that the force is constant at least within that section of  $S$ .

### 3. Experiment

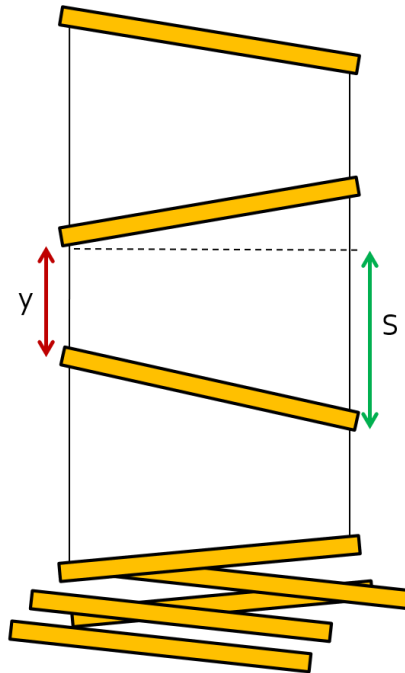

**Figure 6:** Describe the length of  $S$  which is the section of distance moved with constant

#### 3.1 Materials

- Fishing string
- 0.3m rod
- Slow motion camera
- Tracker program



**Figure 7:** 0.3m long, 0.012m radius

### 3.2 Procedure

According to the equation about the new velocity ( $v_{i\ new}$ ), the determining factors of the velocity are number of rods, length of  $y$ , and the angle of the rod tilted. The chain was built with different angles, length of  $y$ , and number of rods.

The chain is made with rods and fishing string. The length of  $y$  and the degree are measured with ruler and protractor. All the measuring is based on the symmetric line that connects the two holes at the each end of the rod in Figure 7. When dropping the chain, make sure the lower end of the bottom rod is touching the horizontal surface and to use a dropping machine because human error may occur if the chain is dropped by hands. The falling chain is filmed in a slow-motion video, and the velocity of the chain falling is tracked with the program called Tracker. Acceleration can also be calculated and graphed using this program.



Figure 8: Chains of different number of rods, different angles, different length of  $y$

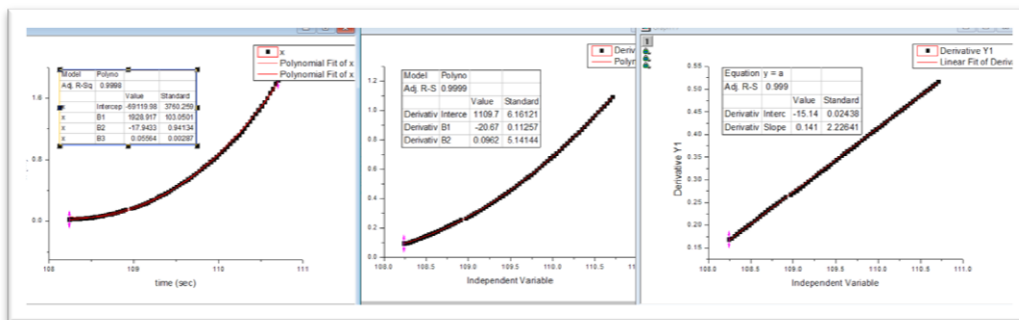

Figure 9: The falling chain was filmed using a slow motion camera, and the data of velocity and acceleration of the falling chain were collected using the program named Tracker



## 4. Analysis & Result

To test the effects of each parameter on the acceleration, only one independent variable was changed and other two was controlled. For example, the first graph below is titled “Acceleration according to degree tilted ( $y=0.1m$ ,  $n=9$ )” which means the independent variable is degree tilted and the length of  $y$  and number of rods were constantly  $0.1m$  and  $9$  throughout the experiment.

### 4.1 Acceleration According to Degree Tilted

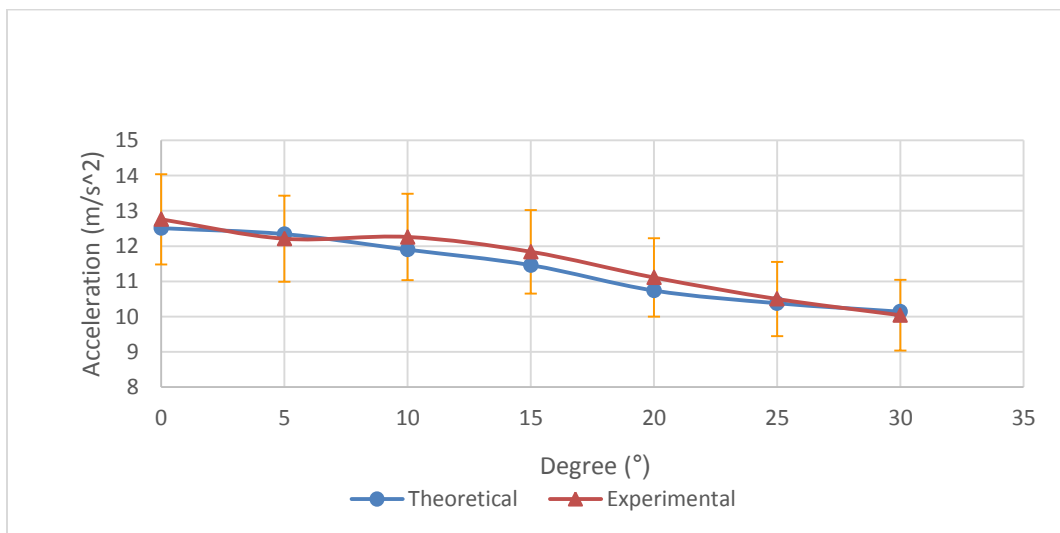

**Figure 9:** Acceleration According to Degree Tilted ( $y=0.1m$ ,  $n=9$ ). Graph representing the relationship between the acceleration of the chain and the degree of the rod tilted

This graph compares the theoretical value and the experimental value of the acceleration according to the change in degree tilted. As the degree tilted increases, the acceleration decreases. If the degree is too large, the opposite point of the rod takes longer time to reach the horizontal surface which may decrease the acceleration of the chain falling.

#### 4.2 Acceleration According to Length of y

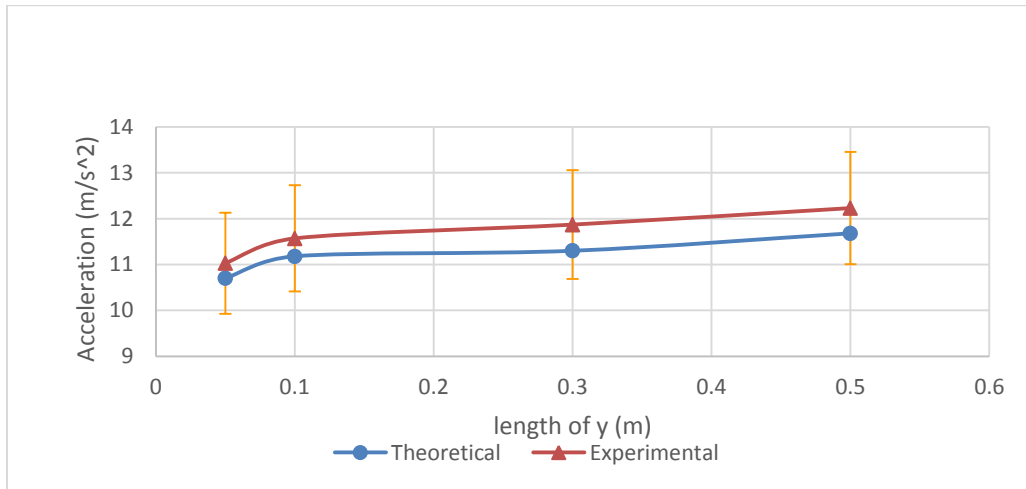

**Figure 10:** Acceleration According to length of y ( $n=9$ ,  $\text{degree}=5^\circ$ ). Graph representing the relationship between the acceleration and the length of y

This graph compares the theoretical value and the experimental value of the acceleration according to the change in length of y (section of free fall). Acceleration increases as the length of the free fall section increases. However, relatively flat graph consists of a limit to the increase of acceleration.

#### 4.3 Acceleration According to Number or Rods

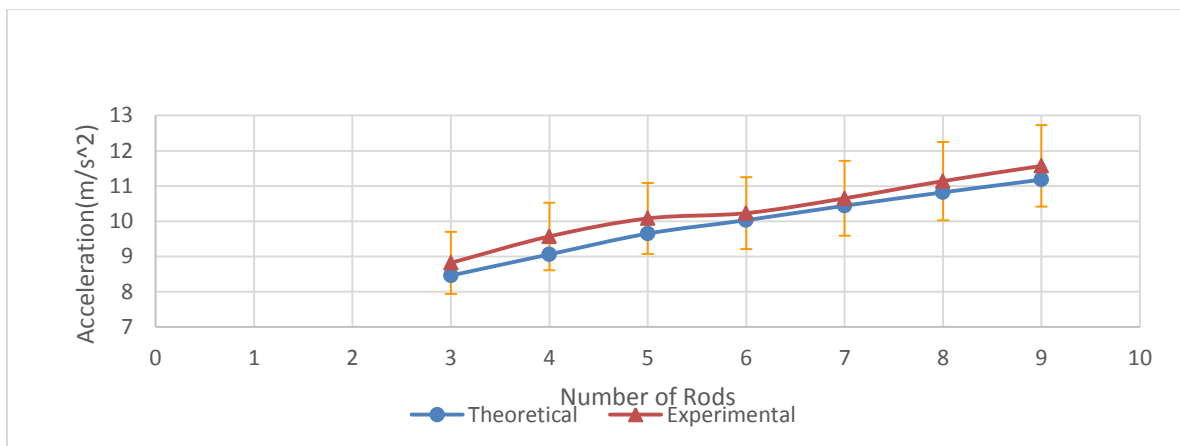

**Figure 11:** Acceleration according to number or rods ( $y=0.1\text{m}$ ,  $\text{degree}=5^\circ$ ). Graph representing the relationship between the acceleration and the number of rods

This graph compares the theoretical value and the experimental value of the acceleration according to the change in number of rods falling. As the number or rods increases on the chain, the average acceleration of the chain also increases. Of course, if there is more collision which is

the causal force of acceleration increasing, then more forces will be acting on the chain and adding more frequently to acceleration.

As the degree tilted increases, the acceleration decreases. According to the equation 13, the acceleration is inversely proportionate to the value of  $\cos\theta$ , in which the  $\theta$  represents the angle of the rod tilted. Meanwhile, acceleration has positive correlation with the length of  $y$  and the number of rods. As the number of rod increases, more collisions occur, pulling down on the connected string and increasing the acceleration of the falling chain.

## 5. Discussion

In order to drive a general equation that explains the fast chain phenomenon, in which a rod-chain falls with acceleration greater than the gravitational acceleration, concepts of linear momentum and angular momentum were used. Angular momentum was used to calculate the value of impulse on the rod during the collision against the horizontal surface. Linear momentum was used to define the velocity of the total chain after each collision.

Overall, the theoretical value of the acceleration and the experimental value of the acceleration shows a similar trend with error bound of  $\pm 10\%$ . The acceleration ranges between  $9.5m/s^2$  and  $12.5m/s^2$ . The chain tends to decrease in acceleration as the angle of the tilted rod gets bigger, but increase in acceleration as the length of  $y$  and number of rods also increases.

The difference between the theoretical acceleration and the experimental acceleration may be an error from assumptions such as sticking collision. In reality, the rod bounces back up several times after it hits the horizontal surface until it loses all its energy. These bouncing rods pulls on the falling chain more than once, which means more impulse could influence the acceleration of the falling chain. Certainly, there are more than one impulse occurring before the rod comes to a full stop on the ground.

In addition, after calculating the theoretical value of the velocity, the acceleration was calculated with an assumption that, within a section, force applied to the chain is constant in order the use the Equation of Motion.

For further research, some values need to be known. We need a better program than Tracker to find the exact changes in displacement. Also, the value of force on the colliding rod during at the instant moment of collision should be measured and utilized to find the impulses.

Lastly, the string mass and tension should be considered and not be assumed to be free falling because string is pulling down the rest of the chains still falling.

## References

- Anoop Grewal, Phillip Johnson, and Andy Ruina (2011). A chain that accelerates, rather than slows, due to collisions: how compression can cause tension, 14853.
- Chatterjee, A., & Ruina, A. (1998). Two Interpretations of Rigidity in Rigid-Body Collisions. *Journal of Applied Mechanics*, 65(4), 894. <https://doi.org/10.1115/1.2791929>
- Grewal, A., Johnson, P., & Ruina, A. (2011). A chain that speeds up, rather than slows, due to collisions: How compression can cause tension *American Journal of Physics*, 79 (7) <https://doi.org/10.1119/1.3583481>
- Hamm, E., & Géminard, J. (2010). The weight of a falling chain, revisited. *American Journal of Physics*, 78(8), 828-833. <https://doi.org/10.1119/1.3429983>
- Mohazzabi, P. (1999). Free fall and angular momentum. *American Journal of Physics*, 67(11), 1017-1020. <https://doi.org/10.1119/1.19163>
- Our chain: Design and Experiments. (2011, March 13). Retrieved November 28, 2017, from [http://ruina.tam.cornell.edu/research/topics/fallingchains/Falling\\_Chain\\_experiments.htm](http://ruina.tam.cornell.edu/research/topics/fallingchains/Falling_Chain_experiments.htm)
- 1
- Rod Cross (2008). Differences between bouncing balls, springs, and rods, Vol 76, No.10.
- S. (2013, April 25). Falling faster than gravity. Retrieved November 28, 2017, from <http://inspiringscience.net/2013/04/15/falling-faster-than-gravity/>
- SantoPietro, D. (2016, July 29). What are elastic and inelastic collisions? (article). Retrieved November 29, 2017, from <https://www.khanacademy.org/science/physics/linear-momentum/elastic-and-inelastic-collisions/a/what-are-elastic-and-inelastic-collisions>
- Wong, C. W., Youn, S. H., & Yasui, K. (2007). The falling chain of Hopkins, Tait, Steele and Cayley. *European Journal of Physics*, 28(3), 385-400. <https://doi.org/10.1088/0143-0807/28/3/001>