

Conference Name: EnSci London 2024 – International Conference on Engineering & Sciences, 19-20 June

Conference Dates: 19-Jun- 2024 to 20-Jun- 2024

Conference Venue: The Tomlinson Centre, Queensbridge Road, London, UK

Appears in: MATTER: International Journal of Science and Technology (ISSN 2454-5880)

Publication year: 2024

Omidiji et al., 2024

Volume 2024, pp. 61-78

DOI- <https://doi.org/10.20319/icstr.2024.6178>

This paper can be cited as: Omidiji, B.V, Daniyan, A. A, Owolabi, H. A, Oluwasegun, K. M, Egbeunmi, D, Falodun, O. E. (2024). Structural Analysis of a Lightweight Electric Vehicle Chassis. EnSci London 2024 – International Conference on Engineering & Sciences, 19-20 June. Proceedings of Scientific and Technical Research Association (STRA), 2024, 61-78.

STRUCTURAL ANALYSIS OF A LIGHTWEIGHT ELECTRIC VEHICLE CHASSIS

B. V. Omidiji

Department of Mechanical Engineering, Obafemi Awolowo University, Ile-Ife, Nigeria
bomidiji@oauife.edu.ng

A. A. Daniyan

Department of Material Science and Engineering, Obafemi Awolowo University, Ile-Ife, Nigeria
adaniyan@oauife.edu.ng

H. A. Owolabi

Department of Mechanical Engineering, Obafemi Awolowo University, Ile-Ife, Nigeria
howolabi@oauife.edu.ng

K. M. Oluwasegun

*Department of Mechanical and Manufacturing Engineering, University of Manitoba, Winnipeg,
Manitoba, Canada*
excetom@gmail.com

D. Egbeunmi

Department of Mechanical Engineering, Obafemi Awolowo University, Ile-Ife, Nigeria
degbeunmi2@huskers.uni.edu

O. E. Falodun

Department of Mechanical Engineering, Obafemi Awolowo University, Ile-Ife, Nigeria
farlodunolusegun@gmail.com

Abstract

This study presents a comprehensive investigation into the design and structural analysis of lightweight chassis for electric vehicles. A chassis needs to be able to withstand twist, shock, vibration, and other stresses caused by acceleration, braking, road condition, and shock initiated by other parts of a vehicle. It should carry a maximum load under all operating conditions. Two materials, 304L steel, and Ti-6AL-4V alloy were evaluated, with parameters such as total deformation, equivalent stress, and equivalent elastic strain under consideration. The outcome of the Finite Element Analysis revealed that Ti-6AL-4V can withstand higher stresses than 304L Steel. By investigating the static behaviors of the chassis under static loading due to weight and overload conditions, Ti-6AL-4V was chosen as a suitable replacement for a 304L Steel chassis.

Keywords:

Electric Vehicle, Chassis, Solidworks, Finite Element Analysis, Ti-6Al-4V

1. Introduction

In recent decades, due to increasing climate crises, ecological disasters, rampant pollution, and the proliferation of plastic waste across our oceans and communities, scientists have looked towards more natural and renewable solutions to these problems. One of such problems is the pollution caused by Internal Combustion Engines and the over-reliance on fossil fuels to power these machines. The amount of greenhouse gas (GHG) emissions is projected to double by 2050 if no steps are taken to reduce the use of fossil fuels (Yong, *et al*, 2015). According to the Environmental Protection Agency (EPA), by 2021, the transportation sector would account for 28% of GHG emissions worldwide (Environmental Protection Agency (EPA)).

Therefore, the focus has shifted to developing new fuels and introducing clean technology in all facets of the transportation sector, to reduce GHG emissions and improve vehicle performance. Electric vehicles are one of such promising solutions that has everyone excited. The development of Electric Vehicles (EVs) has improved energy security by diversifying energy

sources. It has also become a driving force behind a lot of new advanced industries, fostering economic growth in the process, and helping soften the blow to the economy as a result of the transition away from fossil fuels. But most importantly, when it comes to protecting the environment by minimizing tailpipe emissions. EVs show a better performance than internal combustion engine vehicles due to their usage of more efficient power trains, batteries, and electric motors (Yong, *et al*, 2015).

Despite increasing popularity and the rise of electric vehicle manufacturers like Tesla, Lucid, Rivian, and GM, EVs still need some major issues that have prevented them from becoming widely accepted such as mileage, battery storage capacity, weight, battery cost, and charging time. Several solutions have been provided as to how to tackle these problems like researching alternative battery technologies, energy optimization, and weight reduction. It has become clear to everyone from professionals, to industry giants and governments that EVs will have a very important role in the future of transportation as a whole along with shared mobility, autonomous vehicles, and public transportation. Therefore, more efforts are underway to facilitate the charging process and to improve battery capacity. Researchers are working on improved battery technologies to increase driving range and decrease charging time, weight, and cost (Sanguessa, *et al*, 2021). These factors will ultimately determine the future of EVs. Weight reduction is a major focus for a lot of industry giants and it can come in two forms namely, components weight reduction and weight reduction of structural members (Chang-Sheng, *et al*, 2021).

The weight of the vehicle frame, battery, motors, and chassis is important in determining the performance of an electric vehicle. Electric vehicles (EVs) use electricity to power electric motors which then turn wheels to move the entire vehicle. Most EVs utilize onboard batteries to power these motors. But even with recent developments in battery technology, the energy density of these batteries often limits the performance and mileage of these vehicles (Park, *et al*, 2015)

The automotive chassis is the structure of a vehicle that supports the body, engine, and other parts of the car. It is the backbone of a vehicle, which provides the necessary strength and rigidity to support the weight of the car and its passengers and the forces generated during driving (Bardero, 2014). The chassis serves as a frame to which mechanical components like the suspension system, axle, shafts, and wheel are attached. In EVs, the chassis provides attachment points for the wires, and electronic components while also serving as a housing for the battery packs (Huang, *et al*, 2019). In monocoque chassis, the chassis functions as the entire body of the

car, housing the seats, the engine and electronic components, while in ladder frame chassis, they serve as the backbone of the vehicle structure and house the components (Khoo, 2019). Without proper consideration for the housing or attachment, the vehicle design becomes unsustainable. A well-designed chassis will have consideration for the attachment of suspension, driving shafts, wheels, electronic components, seats, and the battery pack while also minimizing the vibrations that will be transferred to these components (Riley and George, 2002)

Chassis is designed to deal with static and dynamic loads, without undue deflection or distortion. The loads that can be experienced by a chassis come in different forms such as static loads and dynamic loads. The chassis also experiences longitudinal loads, inertia loads, cornering loads, and vibrational loads (Wang, 2018). A good chassis should be able to withstand the stresses due to these loads that it is expected to experience without undue deflection, distortion, or plastic deformation. Chassis are designed to withstand certain loads and certain materials can withstand these loads better than others (Shahab, 2019, Liu, *et al*, 2018). To support these components rigidly, the structural design has to be properly considered. The chassis is also subjected to various structural requirements, such as strength, stiffness, and fatigue resistance. Vehicle structures are broken down into different zones for development such as the passenger cell and crumple zone (Khoo, 2019).

This study aims to analyze and optimize a four-seater Electric Vehicle chassis made of lightweight material, using Finite Element Analysis and Modeling software. The main focus is to determine the structural integrity of a chassis for an EV. This design and finite element analysis were made using SOLIDWORKS

2. Materials And Methods

Materials

The Materials and Equipment Deployed in the Work are presented in Table 1.

Table 1: Materials and Equipment

S/N	Material/Equipment	Source	Use
1	Laptop (HP Probook)	Personal Device	For Modelling and Simulation
2	SOLIDWORKS 2018	Dassault Systems	Modeling and Simulation Software

3	Chassis Design	Open Motors	Used as a reference for personal design and modeling
4	304L Steel	SOLIDWORKS materials section	Applied to the model. It possesses high strength and it is lightweight material

Based on the input from open Electric Vehicle design as a reference, the material chosen for the chassis frame is Ti-6AL-4V of 100mm diameter and 100mm thickness. It was selected based on its density, tensile strength, yield strength, and weldability.

Methods

CAD Modelling

By using SOLIDWORKS 2018 software, a suitable chassis model was created with the following specifications presented in Table 2. The mechanical properties of the material are presented in Table 3 as given by SOLIDWORKS 2018. The chassis model created is shown in Figure 1 and the views; top, front, and side are depicted in Figure 2.

Table 2: Chassis Specifications (Source: Openmotors.com)

S/N	Specification	Values (mm)
1	Wheelbase	2350
2	Track Width	1488
3	Height	1200

Table 3: Material Properties

S/N	Material Property	304L Steel	TI-6AL-4V
1	Density (ρ)	7.9 g/cm ³	4.43g/cm ³
2	Young's Modulus (E)	200 GPa	113.8GPa
3	Ultimate Tensile Strength	564 MPa	950Mpa
4	Elongation (ϵ) at break	58%	14%
5	Poisson's Ratio (ν)	0.28	0.33

6	Tensile Yield Strength	190 MPa	870MPa
7	Fatigue Strength	430 MPa	510MPa
8	Shear Modulus	81 GPa	44GPa
9	Shear Strength	370 MPa	550MPa

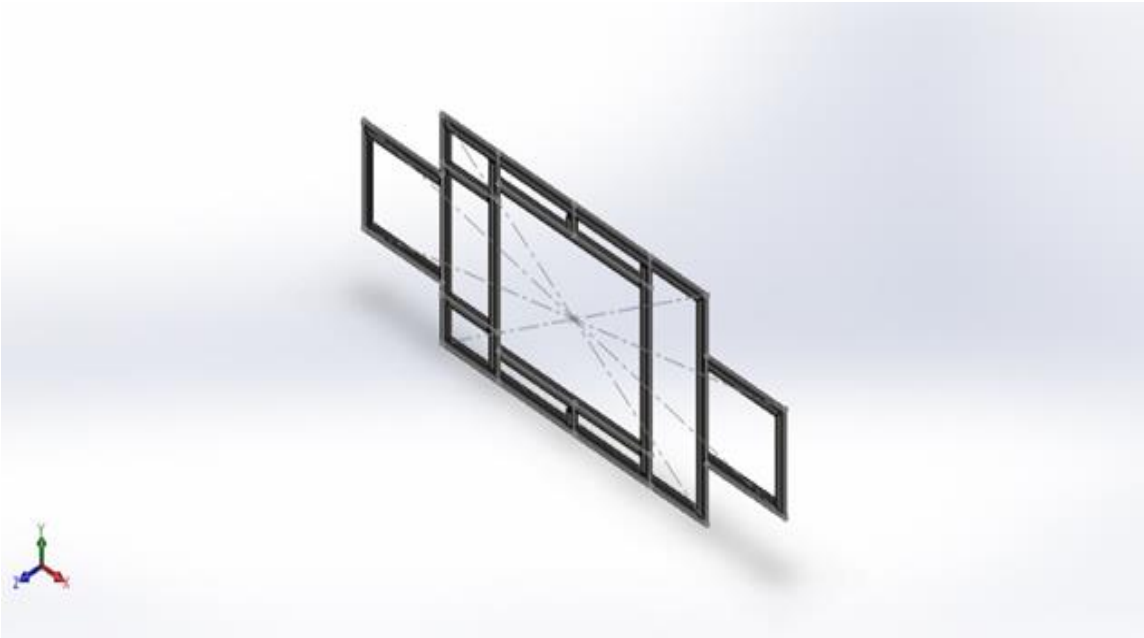

Figure 1: 3D Chassis Model

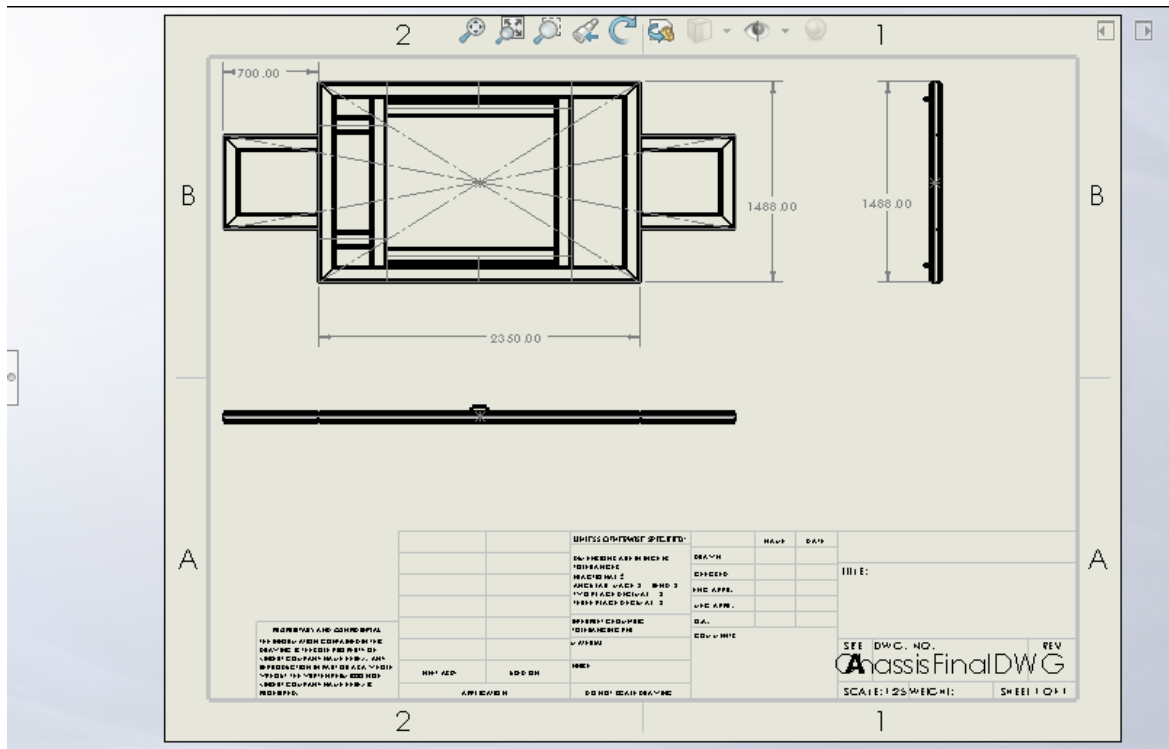

Figure 2: Top, Front, and Side View of the Chassis

3. Results and Discussion

Static Analysis under Load Due to the Weight of the Battery and Components

Static loading results with no passengers are shown in Table 4. In Table 4 the values for the deformation and the VON-Misses stresses experienced by the structural members of two chassis, one built using 304L Steel and the other with Ti-t6AL-4V when subjected to static loading are displayed. The load applied on the chassis is due to the weight of the battery and other components such as the motors, seats, and shafts of the Electric Vehicle. The applied load was 5591.7 N and from the table, it can be seen that in a 304LSteel chassis, it caused a deformation of 0.208mm to the longitudinal members while on a Ti-6AL-4V chassis, it caused a deformation of 0.335 mm. This shows that under the same load, Ti-6AL-4V will have a larger deformation than 304L Steel. It is also seen that the Von-Misses stresses of 304L Steel, compared to its yield strength are higher than that of Ti-6AL-4V. This shows that Ti-6AL-4V is experiencing fewer principal stresses and will be able to sustain more loads before it permanently deforms. Figures 3, 4, 5, and

6 showed the simulation results for VON-Misses stress and deformation of the 304L Steel and Ti-6AL-4V chassis respectively.

Table 4: Load due to weight of battery and other components

Material	Deformation mm	Von Mise Stress N/m ²	Yield Strength N/m ²
304L Steel	0.208	1.1263e+03	2.068e+08
TI-6AL-4V	0.335	9.4000e+02	8.274e+08

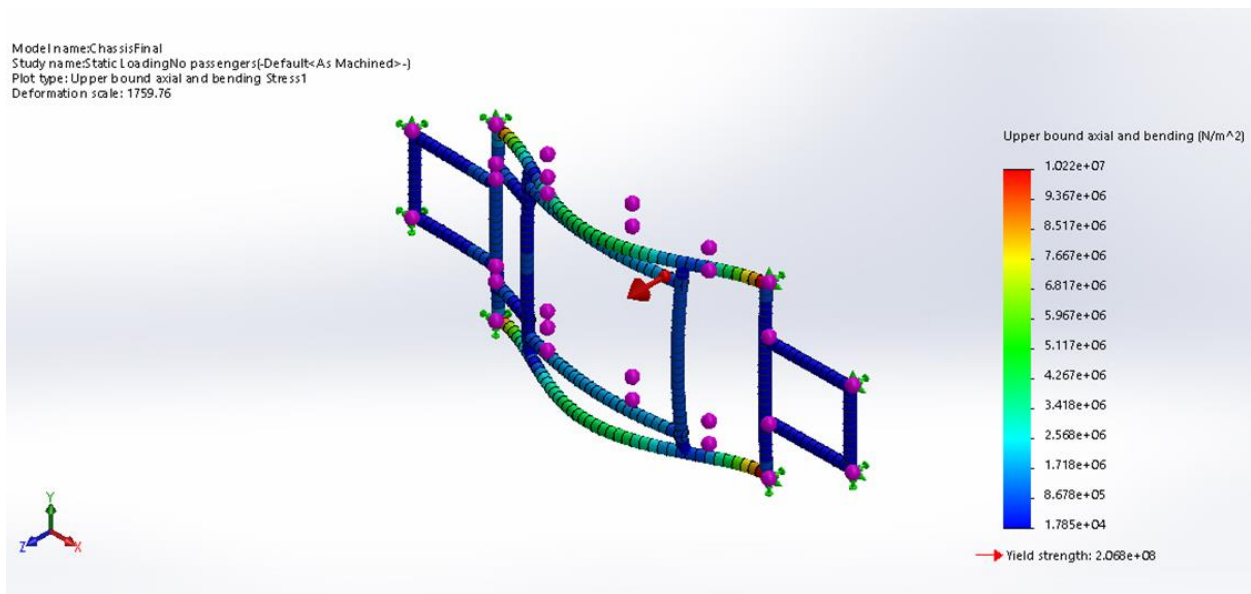

Figure 3: Equivalent Stress for 304L Steel

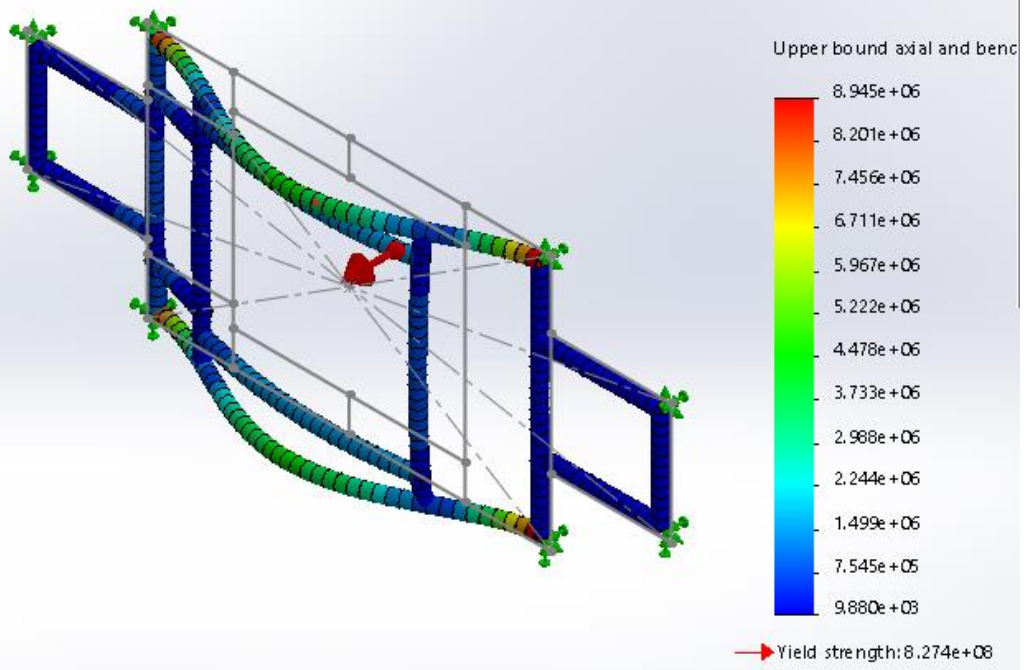

Figure 4: Equivalent Stress for TI-6AL-4V

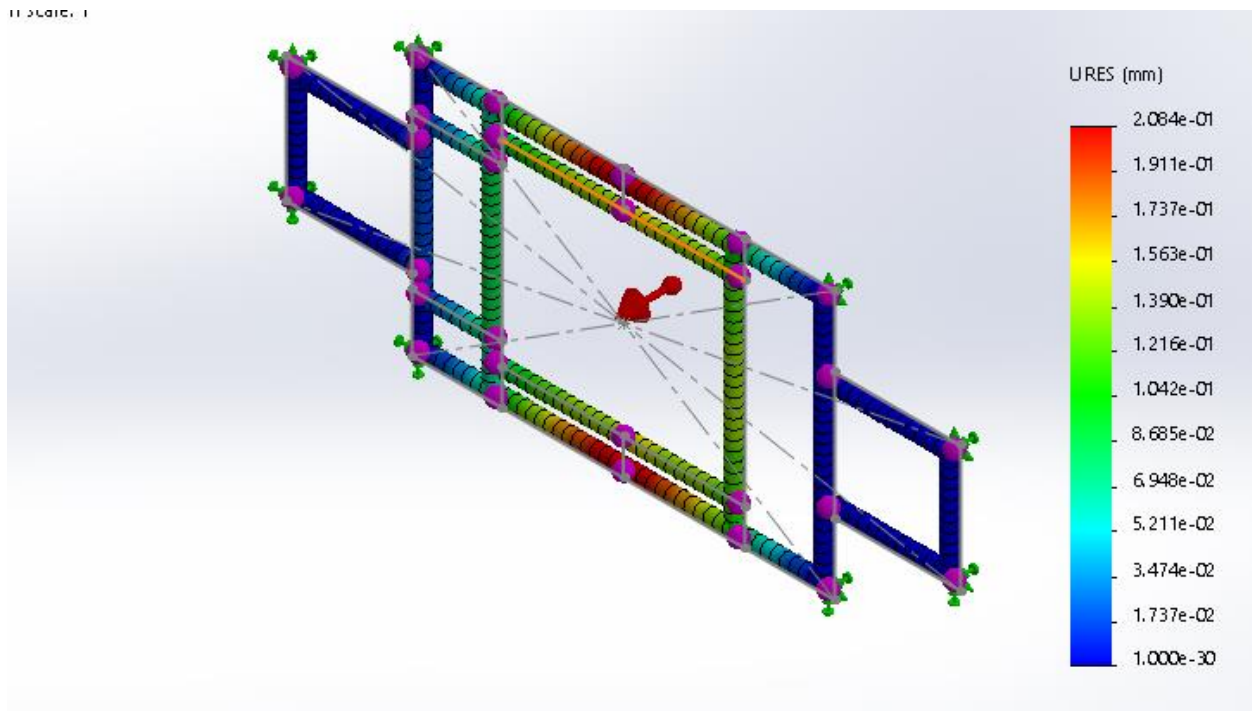

Figure 5: Total Deformation for 304L Steel

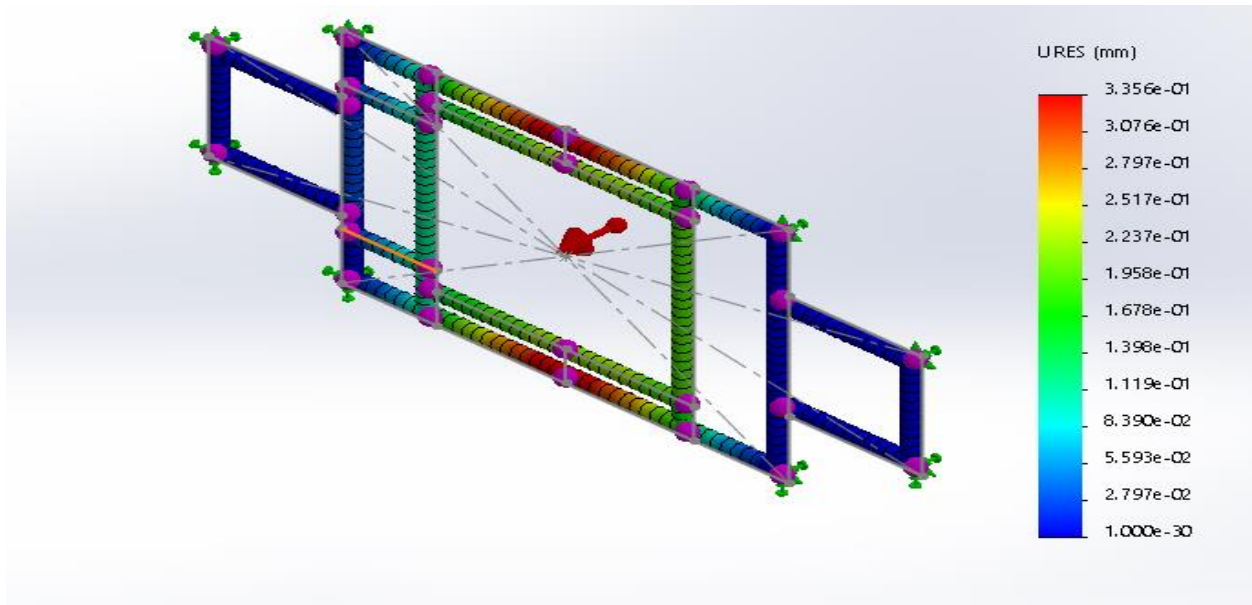

Figure 6: Total Deformation for TI-6AL-4V

Static Analysis under Load Due to Occupants

Table 5 shows the values for the deformation and the VON-Misses stresses experienced by the structural members of the two chassis when subjected to static loading. The load applied on the chassis is due to the weight of the battery and other components such as the motors, seats, and shafts of the Electric Vehicle, and the weight of the passengers. This chassis was designed for 4 passengers and the weight of each passenger was taken as 75kg respectively. The average weight of a North American male according to BioMed Central (BMC) Public Health Authority is around 75-80Kg. The load on the chassis is derived from this weight and Table 5, it can be seen that on the 304L Steel chassis, it caused a deformation of 0.318mm to the longitudinal members, while on a Ti-6AL-4V chassis, it caused a deformation of 0.5339 mm to the longitudinal members. This shows that under the same load, Ti-6AL-4V will have a larger deformation than 304L Steel. From the Table, it can also be seen that the Von-Misses stresses of 304L Steel, compared to its yield strength are higher than that of Ti-6AL-4V. This shows that Ti-6AL-4V is experiencing fewer principal stresses and will sustain a greater load before it permanently deforms. Figures 7, 8, 9, and 10 showed the simulation results for VON-Misses stress and deformation of the 304L Steel and Ti-6AL-4V chassis respectively.

Table 5: Static Loading Results with Four Passengers

S/N	Materials	Displacement (mm)	VON Misses Stress (N/m ²)	Yield Strength (N/m ²)
1	304L Steel	0.318	1.6241e+03	2.068e+08
2	TI-6AL-4V	0.5339	1.4377e+03	8.274e+08

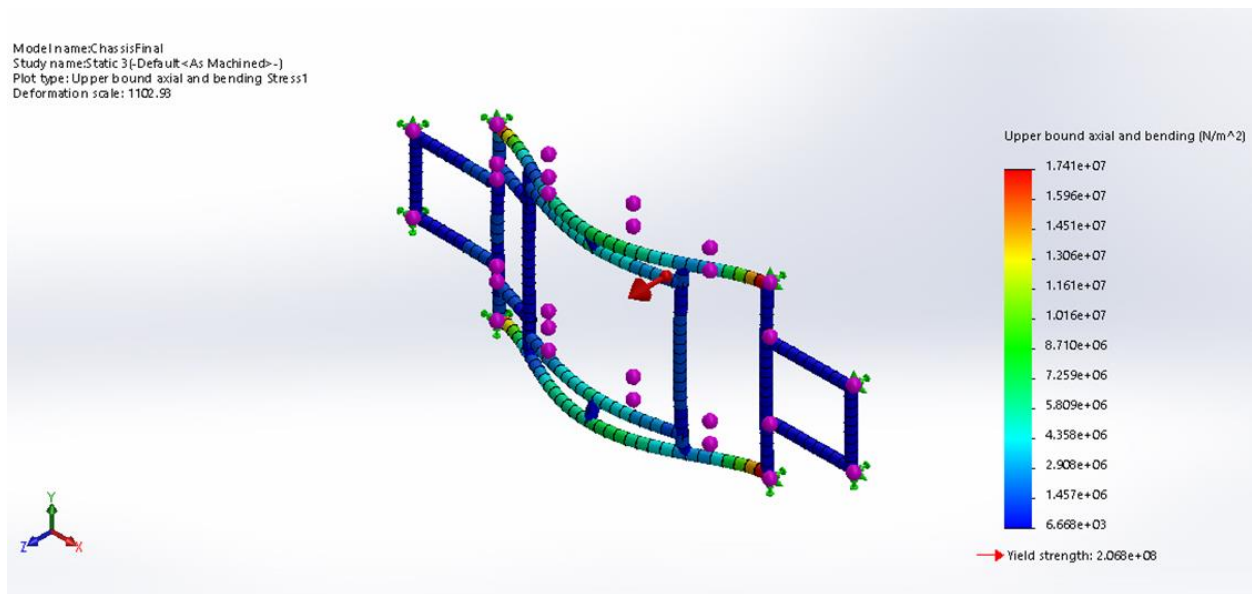

Figure 7: Equivalent Stress for 304L Steel

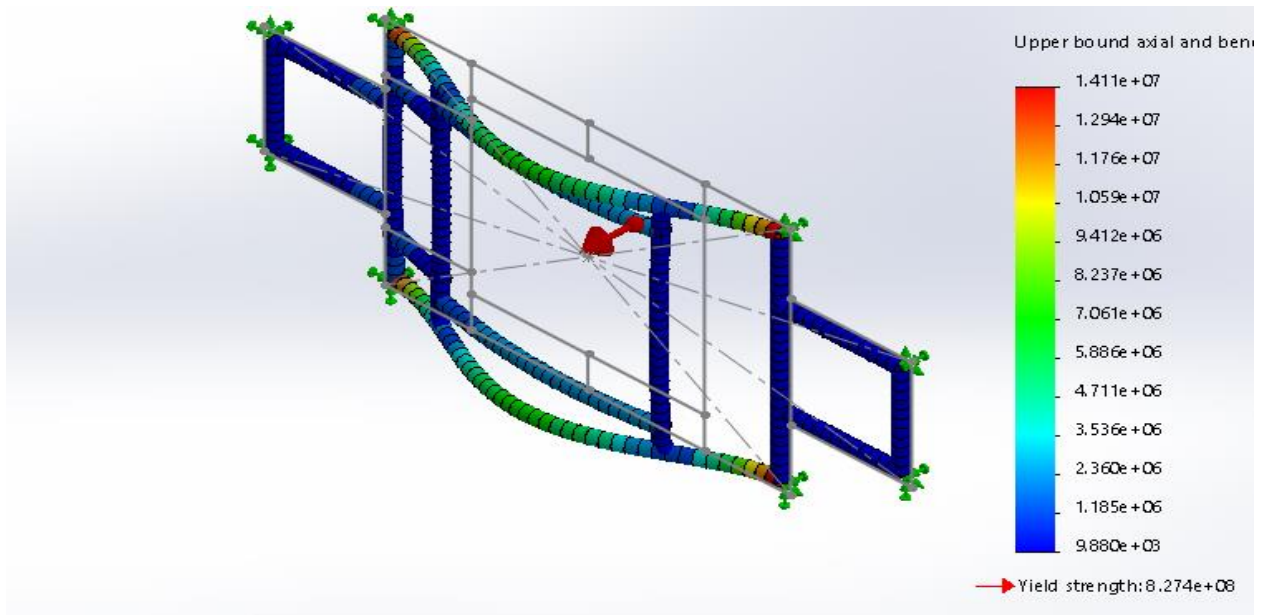
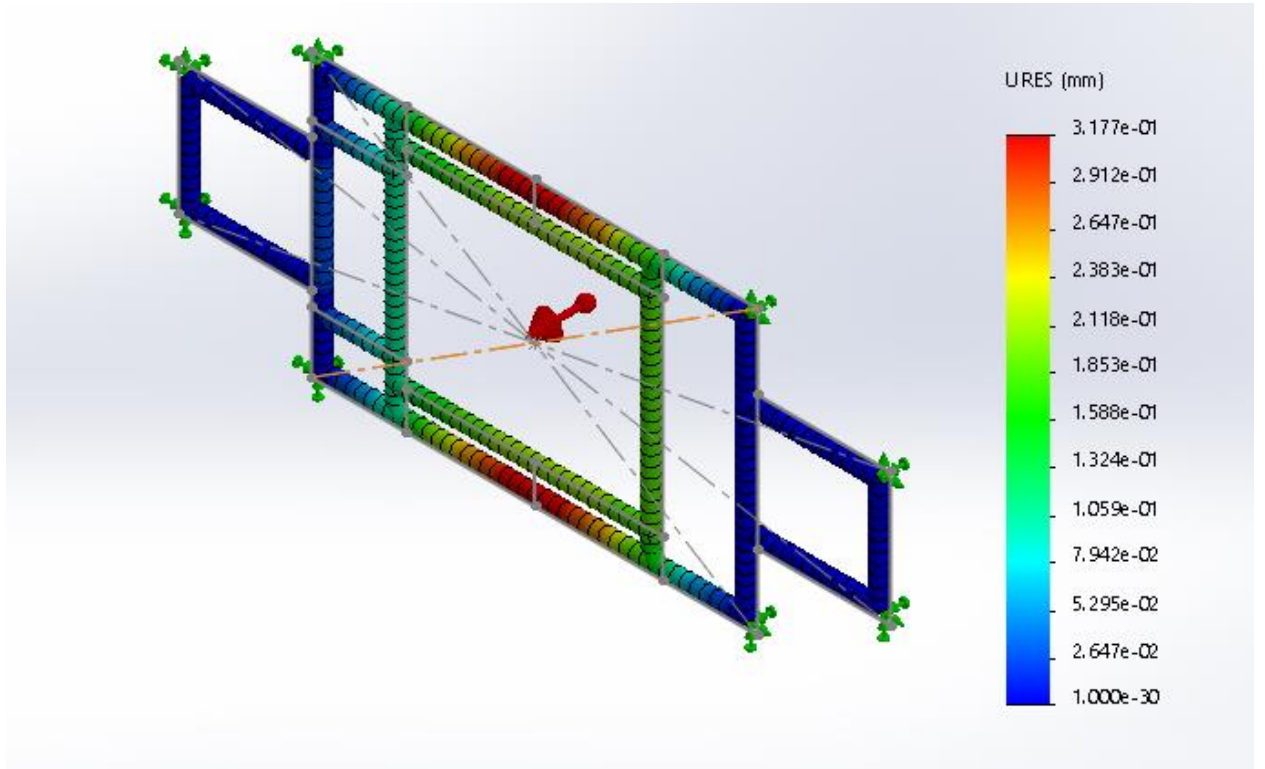

Figure 8: Equivalent Stress for TI-6AL-4V



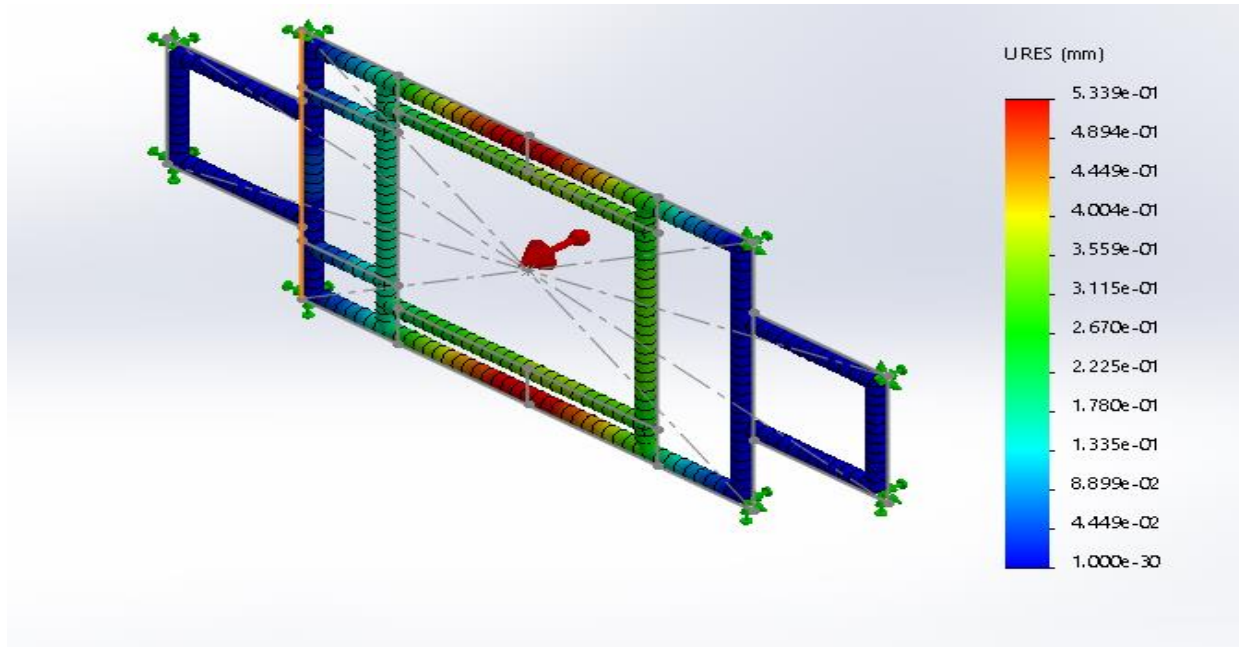

Figure 9: Total Deformation for 304L Steel

Figure 10: Total Deformation for TI-6AL-4V

Static Analysis of Overload

Table 6 shows the values for the deformation and the VON-Misses stresses experienced by the structural members of the two chassis when subjected to static loading. The load applied on the chassis is due to the weight of the battery and other components such as the motors, seats, and shafts of the Electric Vehicle, the weight of the passengers, and overload. Overload is needed for situations like towing or for carrying heavy cargo. This chassis was designed for 4 passengers and the weight of each passenger was taken as 75kg respectively. The overload used for this analysis was 120% of the total load on the car, all four passengers included. This is the average weight of a North American male according to BMC Public Health, weight taken as 75-80Kg. The applied overload was 190314 N and from Table 6, it can be seen that in a 304LSteel chassis, it caused a deformation of 0.33mm to the longitudinal members while on a Ti-6AL-4V chassis, it caused a deformation of 0.630 mm to the longitudinal members. This shows that under the same load, Ti-6AL-4V will have a larger deformation than 304L Steel. From the Table, it can also be seen that the Von-Misses stresses of 304L Steel, compared to its yield strength are higher than that of Ti-

6AL-4V. This shows that Ti-6AL-4V is experiencing fewer principal stresses and will be able to sustain more loads before it permanently deforms. Figures 11, 12, 13, and 14 show the simulation results for VON-Misses stress and deformation of the 304L Steel and Ti-6AL-4V chassis respectively.

Figure 15 shows a graph of the Von-misses stresses experienced by 304L Steel and Ti-6AL-4V respectively due to the load applied. The graphs show the trend in the increase of the stresses as the applied load increases. It also shows that the stresses experienced by 304L Steel and Ti-6Al-4V increase at nearly the same rate. Figure 16 shows the graph of the deformation of a 304L Steel and Ti-6Al-4V chassis against the load applied. It shows that the deformation experienced by the Ti-6Al-4V chassis is greater than the 304L Steel chassis.

Table 6: Static Loading Due to Overload

S/N	Material	Displacement mm	VON Misses Stress N/m ²	Yield Strength N/m ²
1	304L Steel	0.330	1.8567e+03	2.068e+08
2	TI-6AL-4V	0.630	1.6683e+03	8.274e+08

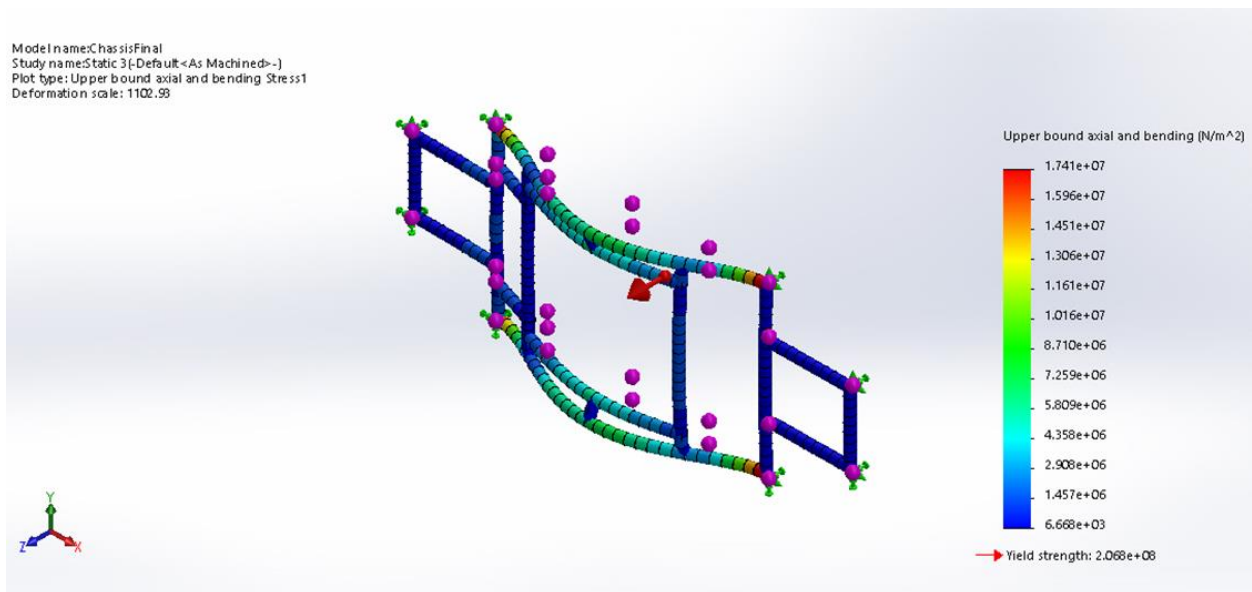

Figure 11: Equivalent Stress for 304L Steel

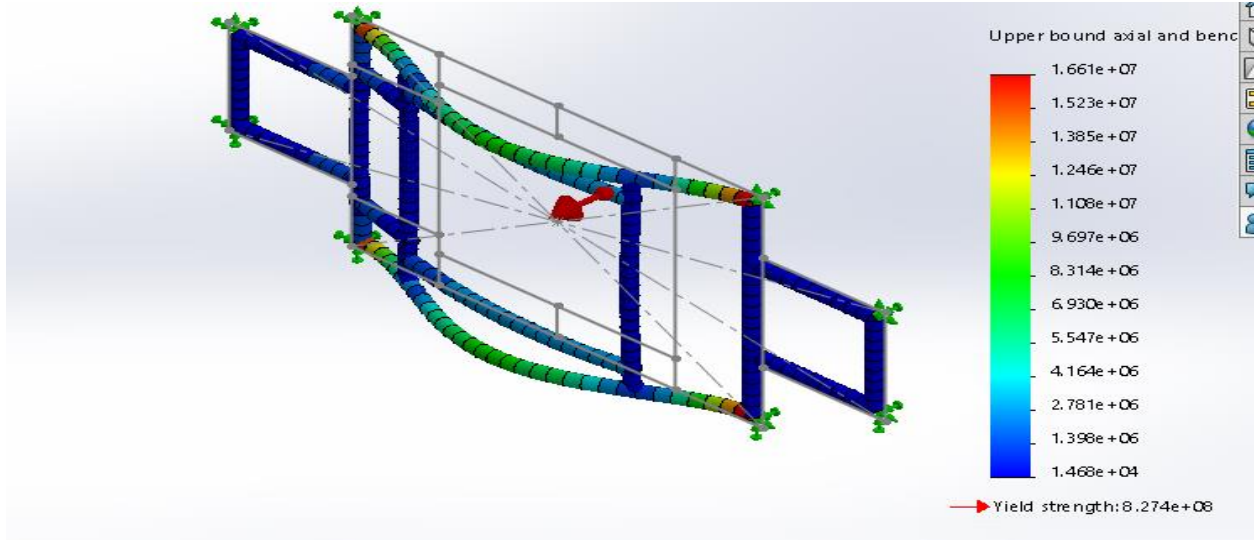

Figure 12: Equivalent Stress for TI-6AL-4V

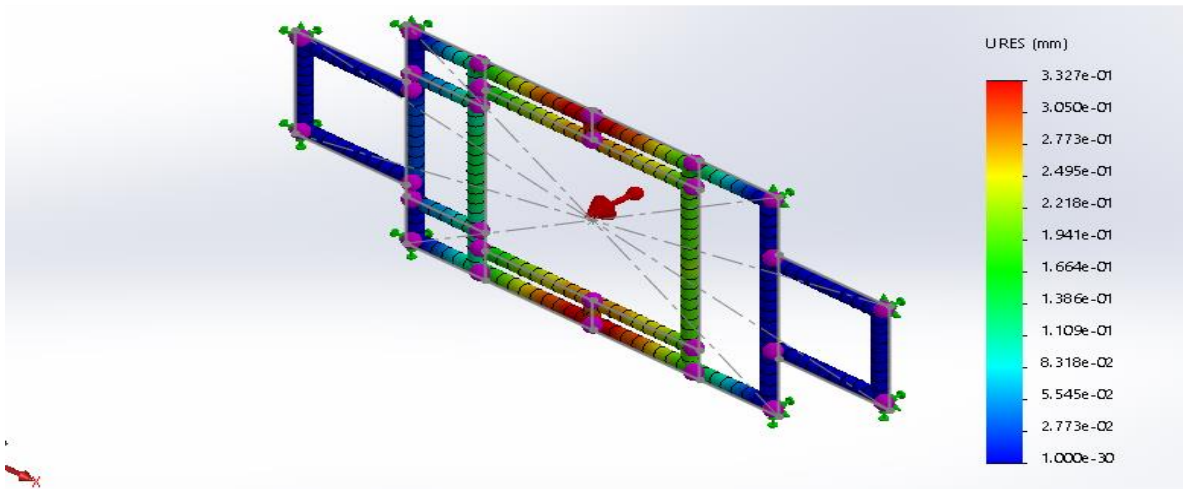

Figure 13: Total Deformation for 304L Steel

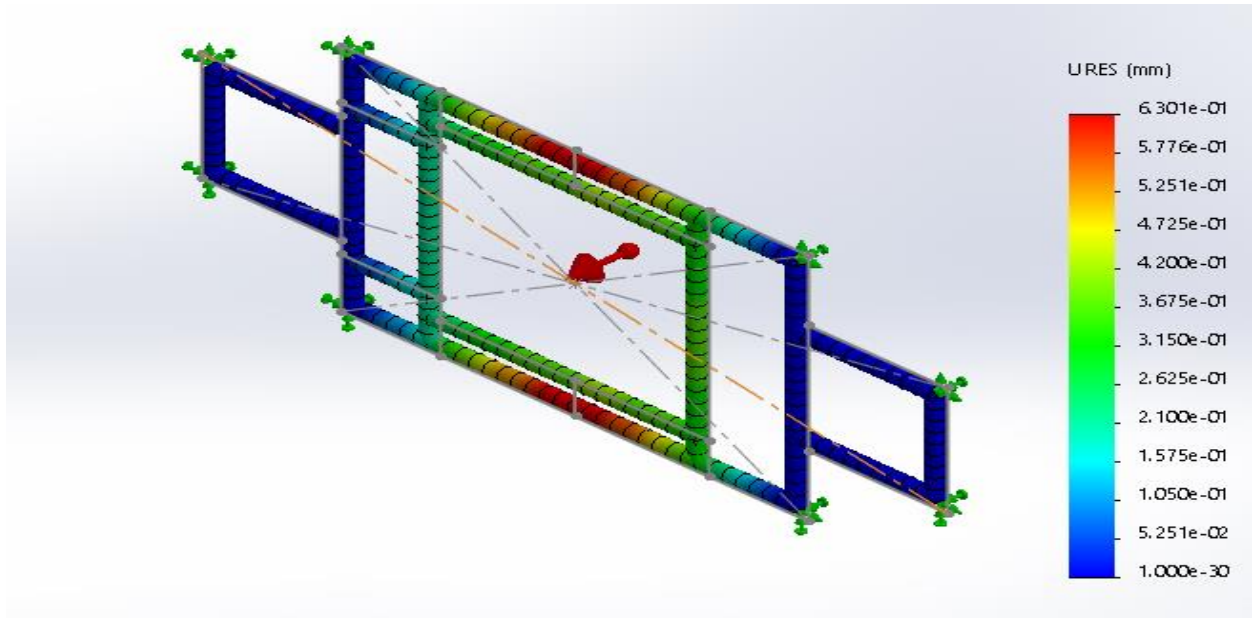

Figure 14: Total Deformation for TI-6AL-4V

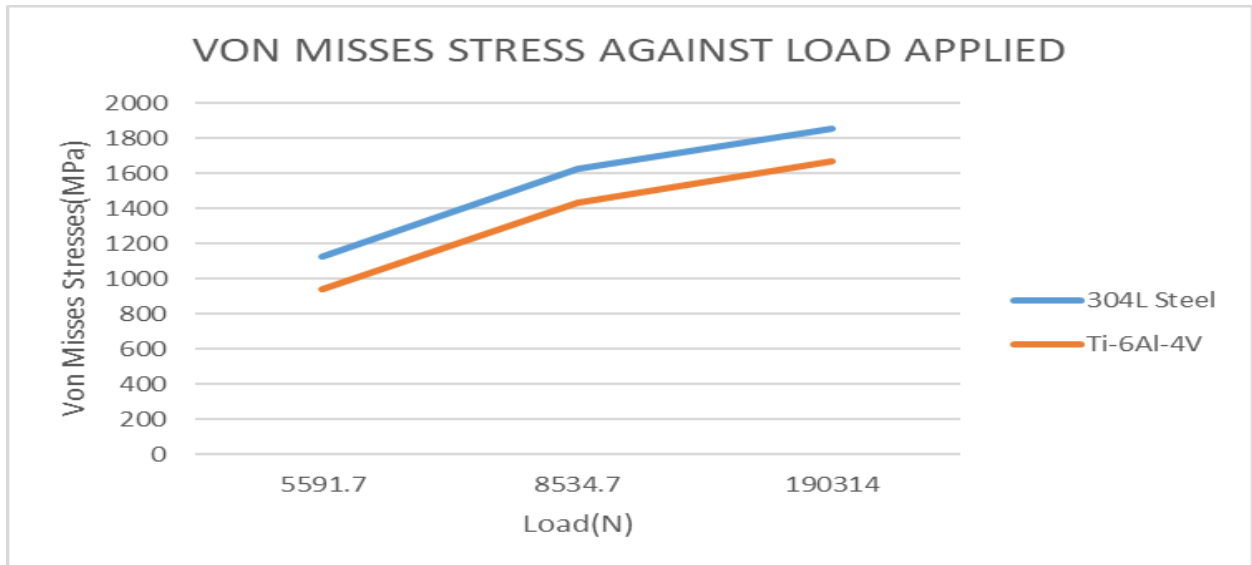

Figure 15: Graph showing Equivalent Stress Against Load Applied

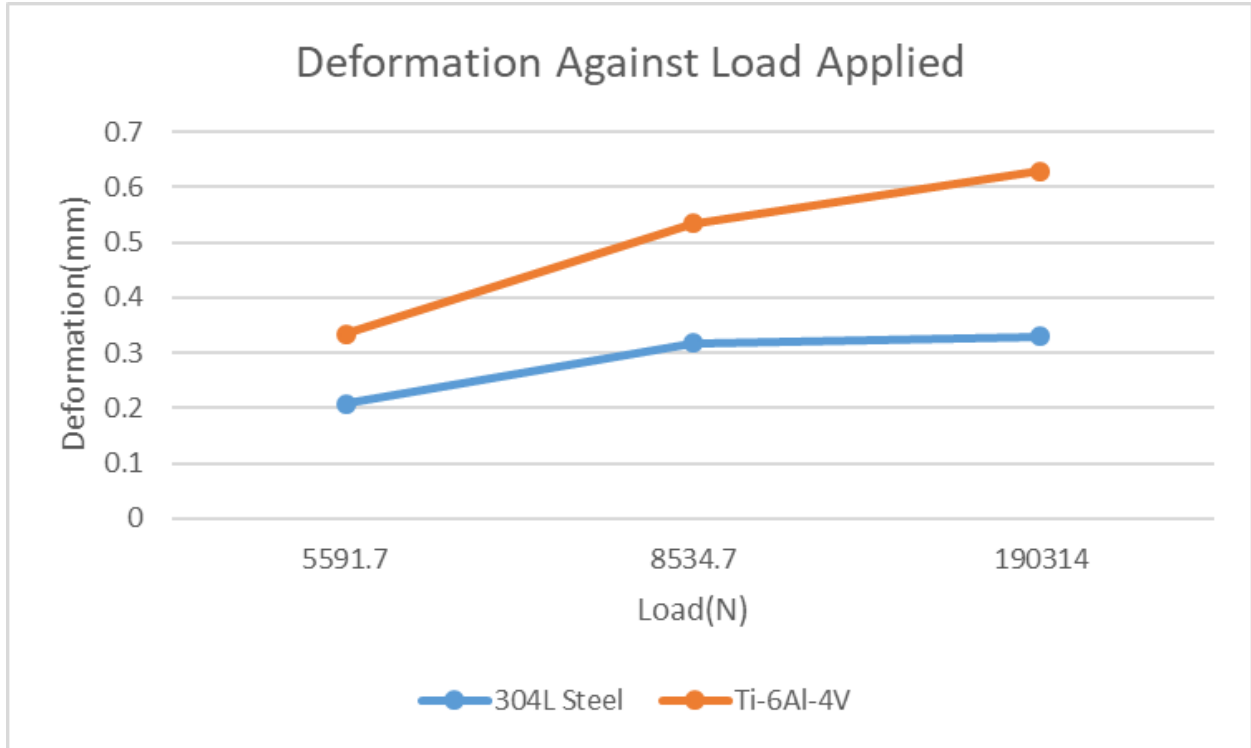

Figure 16: Graph Showing Deformation Against Load Applied

4. Conclusion

Static analysis was done effectively utilizing the finite element analysis technique to find the maximum deformations and stresses and their position on the chassis. The chassis strength was effectively analyzed during normal loading and overload conditions using 304L steel and TI-6AL-4V as the chassis material. The evaluation of the results showed the following;

- (i) From Fig 15 and Fig 16, the deformation & stresses were found to be under the limit for both materials, and the rate of increase of the von-misses stress and deformation was found to be equal.
- (ii) Based on the above results and other parameters like cost, and weight, it was decided that T1-6AL-4V was a more suitable material to use upon considering the various factors such as the total deformation, and equivalent stress.
- (iii) The total deformation might be higher compared to 304L steel but it makes up for it in terms of weight and fatigue strength. The applied overload was 190314 N and from Table 6, it can be

seen that in a 304LSteel chassis, it caused deformation of 0.33mm while on a Ti-6AL-4V chassis, it caused deformation of 0.630 mm.

(iii)The total weight of the chassis when using 304L steel was 365.56kg compared to the 202.25kg Ti-6AL-4V, an almost 44.7% reduction in weight, and reducing weight improves the efficiency of the electric car.

References

- Bardero, E. J. (2014). Finite Element Analysis of Composite Materials using ANSYS. 2nd Edition. CRS Press. Taylor and Francis Group. Boca Raton
- Chang-Sheng, H. and Chang-Chen, Y., Yue-Hao, G. Yi-Xiu, W., Chuan-Hsing, H., and Yi-Ting, L. (2021). Design and Analysis of a Light Electric Vehicle. *Mechanical Sciences*. 12(1). 345-360
- Huang, X., Li, W. and Fang, F. (2019). Design and Analysis of a Lightweight Chassis for Electric Vehicles Based on Topological Optimization. *Journal of Mechanical Science and Technology*, 33(10). 5001-5008
- Khoo, R. R. (2015). Design, Development and Analysis of a Full Carbon Fibre Reinforced Composite Chassis of an Electric Vehicle. Master's Thesis, Nanyang Technological University, Singapore
- Liu, Y. Chen, B. and Shi, W. (2018). Suspension Optimization Design and Virtual Prototype Simulation Analysis of FSAE Racing Car. Proceedings of the 2018 IEEE 4th Information Technology and Mechatronics Engineering Conference (ITOEC), Chongqing, China, 14–16
- Park, J., Park, J. Lee, J. Yi, Y.S. and Park, T. (2015). Analysis of Sensitivity and Optimization for Chassis Design Parameters on the X-Wind Stability. Proceedings of the 18th Asia Pacific Automotive Engineering Conference, Melbourne, Australia, 10–12
- Riley, W. B. and George, A. R. (2002). Design, Analysis and Testing of a Formula SAE Car Chassis. Proceedings of the 2002 SAE Motorsports Engineering Conference and Exhibition, 2; 380.
- Sanguesa J, A., Torres-Sanz, V., Garrido, P., Martinez, F. T. and Marquez-Barja, J. M. (2021). A Review on Electric Vehicles: Technologies and Challenges. *Smart Cities. MDPI*. 4. 372-400.

- Shahab, S. M., Ahmed, S. S. and Ahmed, M. (2019). Design and Analysis of a Lightweight Chassis for an Electric Vehicle using Aluminum and Composite Materials, *International Journal of Automotive and Mechanical Engineering*, 16(4), 6520-6532
- Wang, T. K. (2018) Design of a Lightweight Chassis for Electric Vehicles Using a Topology Optimization Method. *Journal of Mechanical Design*, 140(2). 021404-1-021404-10
- Yong, J. Y., Ramachandramurthy, V. K., Tun, K. M. and Mithulananthan, N. (2015). A Review of the State of the Art Technologies of Electric Vehicles, Its Impact and Prospects. *Renewable and Sustainable Energy Reviews*, Elsevier, 49(c). 365-385